



8.5M GUARDIAN
PATROL & INTERCEPTION VESSEL

NAUTIC[®]

www.nauticafrica.com



8.5M GUARDIAN

PATROL & INTERCEPTION VESSEL

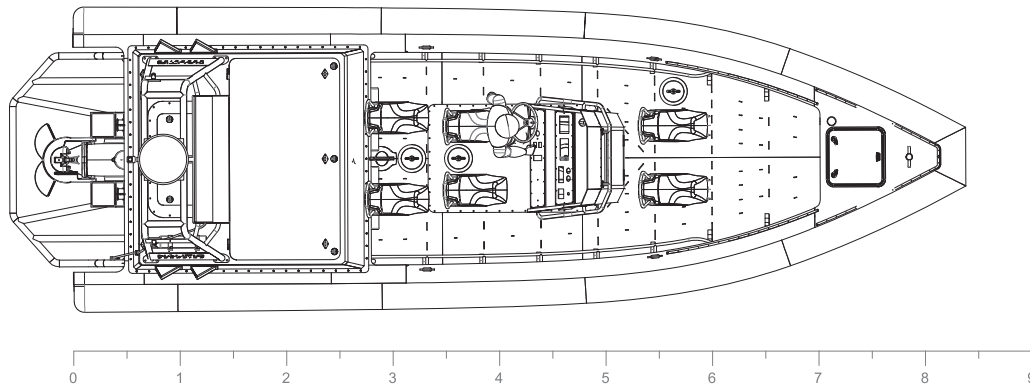
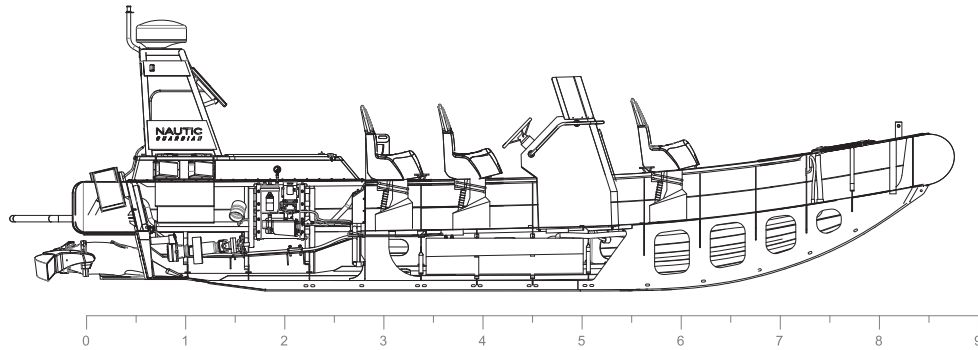
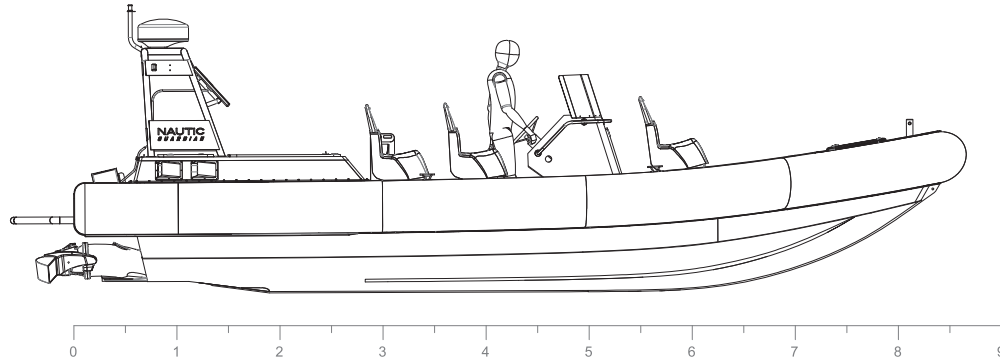

PARTICULARS

Hull / Superstructure	Aluminium
Length (LOA)	8.5 m
Beam (BOA)	2.8 m (Including Fenders)
Draft	0.60 m (Approx)
Displacement (Max)	3.5 T
Flotation Collar	Solid Core Foam

PERFORMANCE

Max Speed	40 knots
Cruise Speed	20 knots
Range	250 nm @ 20 knots

PROPULSION

Engines	1 x Marine Diesel VGT450
Propulsion	1 x DOEN DJ110 Waterjet
Power	1 x 336 kW

CAPACITIES

Fuel	390 L
Complement	2 Crew + 4 Passengers

NAVIGATION AND COMMUNICATION

VHF with DSC
Radar 2kW 4G Broadband
GPS/Chart Plotter
Magnetic Compass
Handheld VHF's (x 1)

SAFETY

Engine Compartment Fire Suppression
Self-Righting Bag
Davit Single Point Lifting